

HEAT RECOVERY AIR HANDLING UNITS

Series VENTS VUE P3B EC



Heat recovery air handling units with max. air capacity **400 m³/h** and heat recovery efficiency up to **85 %**.

■ Application

The VUE P3 B air handling units are the fully featured ventilation units with heat recovery for air filtration, fresh air supply and stale air extract. The heat contained in the extract air is recuperated in the high-efficient plate heat exchanger to warm up supply air. Compatible with round Ø 100 or 150 mm round air ducts.

■ Design

The casing is made of polymer coated steel panels, internally lined with 5 or 10 mm heat- and sound-insulating layer of cellular polyurethane, depending on modification.

The removable service panel on the bottom ensures access for maintenance of the filters and the heat exchanger.

The connecting spigots are located on sides of the unit casing and are rubber sealed for airtight connection to the air ducts.

The fixing brackets attached to the casing enable suspended installation to the ceiling.

■ Fans

High-efficient electronically-commutated motors with external motor. VUE 150 P3B and VUE 250

P3B are equipped with centrifugal impellers and forward curved blades.

VUE 350 P3B EC are equipped with centrifugal impellers and backward curved blades. Such motors are the most state-of-the-art energy saving solution.

EC motors are featured with high performance and total speed controllable range. High efficiency reaching 90% is the premium advantage of the electronically-commutated motors.

■ Heat recovery

Plate enthalpy cross-flow heat exchanger made of polymerized cellulose with heat exchange efficiency from to 85 %.

The enthalpy heat exchanger enables not only heat, but also humidity recovery, thus maintaining stable indoor humidity.

In the summer period the intake air is cooled down and dehumidified and in the winter period it is warmed up and humidified.

Water vapour from the humid extract air is condensed and absorbed by the heat exchanger plates. The recovered humidity and heat are transferred to the supply air flow. The air streams are fully separated within the heat exchanger and the microbes and smells are isolated.

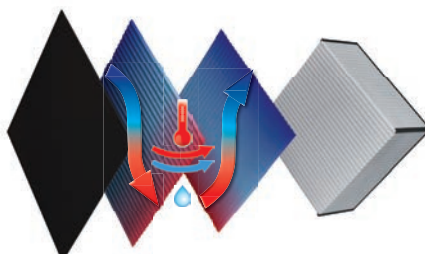

■ Bypass

The units are equipped with the a bypass for summer ventilation (cooling of the premise with a cool outside air).

■ Air filtration

Efficient supply air filtration with two built-in G4 and F8 panel filters. Extract air filtration with a built-in panel G4 filter.

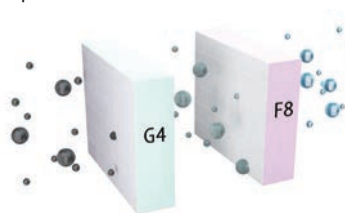

■ Control and automation

VENTS VUE P3B EC A14 units incorporate an integrated control system and A14 wall-mounted touch screen control panel with LED indication.

The units are equipped with the Type B USB Connector for setup of advanced parameters via a specially designed software.



The standard delivery set includes a 10 m cable for connection of the unit and the control panel.

A14 automation functions:

- ▶ Turning the unit on/off.
- ▶ Air capacity control (setting low, medium or high speed).
- ▶ Bypass damper opening/closing for summer ventilation.
- ▶ Alarm indication.
- ▶ Filter maintenance indication.

Extra functions of the A14 automation with the installed software:

- ▶ Fan speed control from 0 to 100 %. Each speed is individually adjusted for the supply and the exhaust fans.
- ▶ Operation control on feedback from HV-2 duct humidity sensor (separate order).
- ▶ Unit operation setting according to the external control relay (separate order).
- ▶ Temperature setting for freeze protection system activation.
- ▶ Control and setup of the filter timer to remind about the filter maintenance.
- ▶ Error code display.
- ▶ Software upgrading.
- ▶ Control of external relay, bypass and humidity control.

■ Mounting

Due to low height of the casing the units offer the optimum solution for the suspended ceiling installation in limited installation space.

The installation place must provide sufficient service access to the unit.

Designation key

Series	Rated air capacity [m ³ /h]	Mounting type	Casing modification	Bypass	Motor type	Control panel
VENTS VUE	150; 250; 350	P: suspended	3: low-profile unit	B: integrated bypass	EC: synchronous electronically commutated motor	A14

Overall dimensions

Model	Overall dimensions [mm]														
	Ø D	A	A1	A2	B	B1	B2	H	H1	L	L1	L2	L3	L4	L5
VUE 150 P3B EC A14	99	947	854	676	704	743	793	227	247	480	92	128	25	113	113
VUE 250 P3B EC A14	149	947	854	676	704	743	793	227	247	480	92	128	25	113	88
VUE 350 P3B EC A14	149	1117	1024	846	754	793	843	277	297	488	109	153	50	88	138

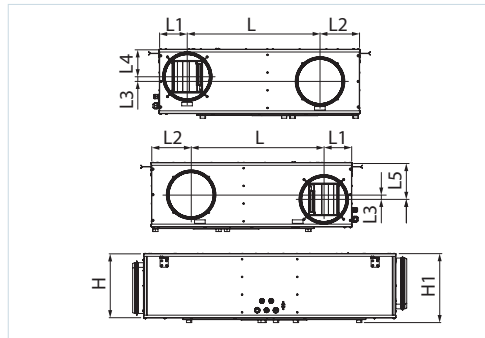
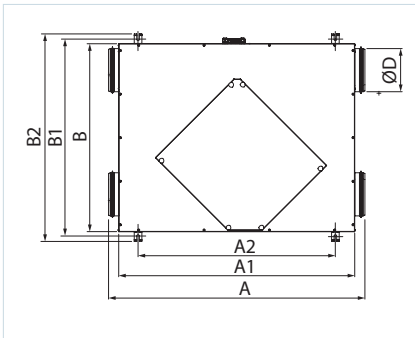

Technical data

Parameters	VUE 150 P3B EC A14	VUE 250 P3B EC A14	VUE 350 P3B EC A14
Unit supply [V/50-60 Hz]		1~ 230	
Max. unit power [W]	70	84	171
Max. unit current [A]	0.6	0.7	1,3
Max. air capacity [m³/h]	180	300	430
RPM [min ⁻¹]	1925	2000	3200
Noise level at 3m [dBA]	32	36	46
Transported air temperature [°C]	from -25 to +40		
Casing material	polymer coated steel		
Insulation thickness	5 mm, 10 mm polyurethane foam		
Extract filter	G4		
Supply filters	G4 and F8 (PM2.5 93 %)	G4 and F8 (PM2.5 83 %)	G4 and F8 (PM2.5 87 %)
Connected air duct diameter [mm]	Ø 100	Ø 150	Ø 150
Heat recovery efficiency [%]	68 - 82	63 - 73	68 - 85
Humidity recovery efficiency [%]	22 - 41	16 - 27	19 - 34
Heat exchanger type	cross-flow		
Heat exchanger material	polymerized cellulose		
Weight [kg]	26	29	42
SEC class	A	B	A

Accessories for AHU

Model	G4 panel filter	F8 panel filter	Internal humidity sensor (0-10 V)	External CO ₂ sensor	External CO ₂ sensor with indication	External humidity sensor	Hydraulic kit	Air dampers	Electric actuator
VUE 150 P3B EC A14	SF 300x220x48	SF 300x220x48							
VUE 250 P3B EC A14	G4	F8	HV2	CO2-1	CO2-2	HR-S	SG-32	KRV 100	LF230
VUE 350 P3B EC A14	SF 300x270x48	SF 300x270x48						KRV 150	
	G4	F8							

HEAT RECOVERY AIR HANDLING UNITS

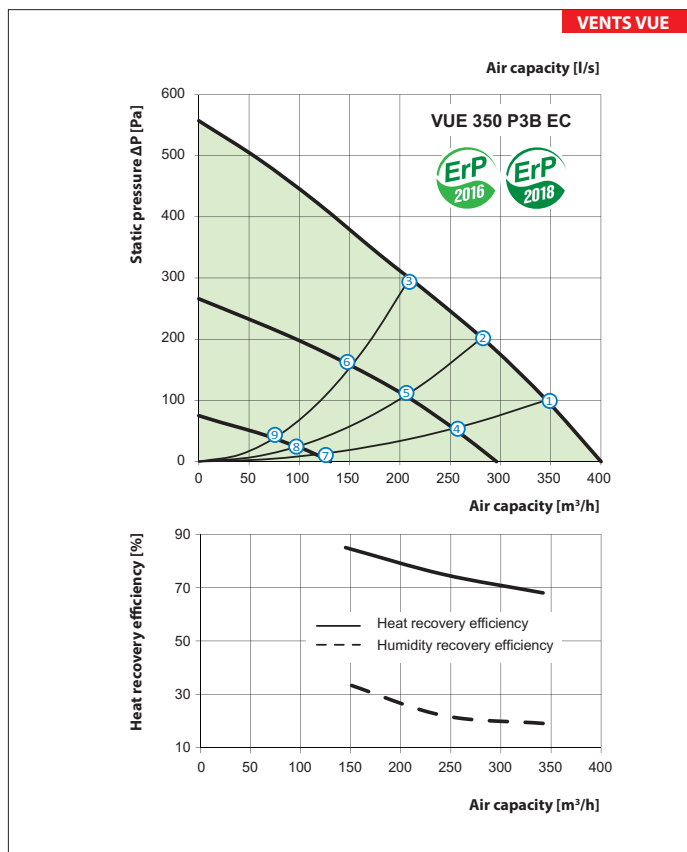
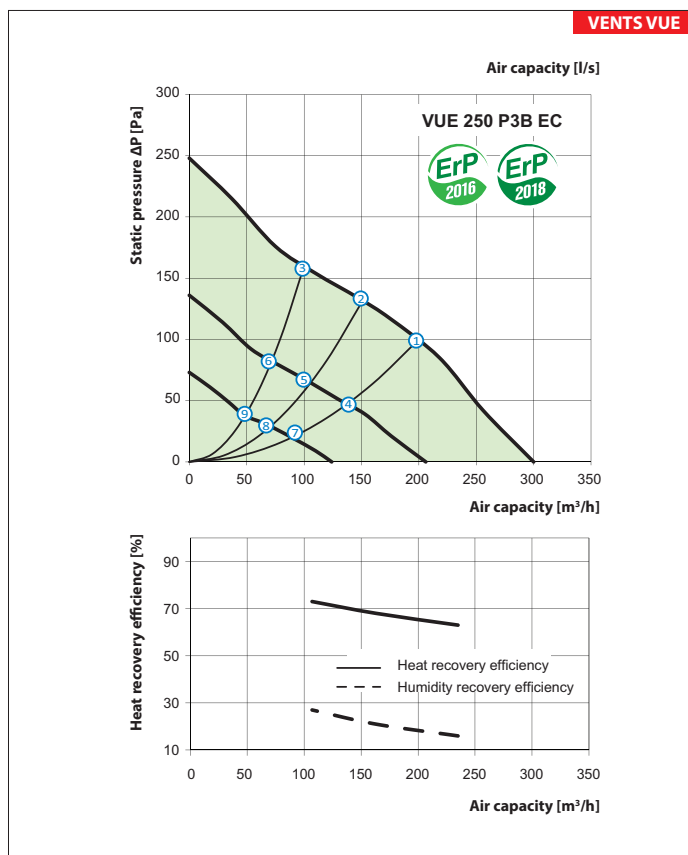
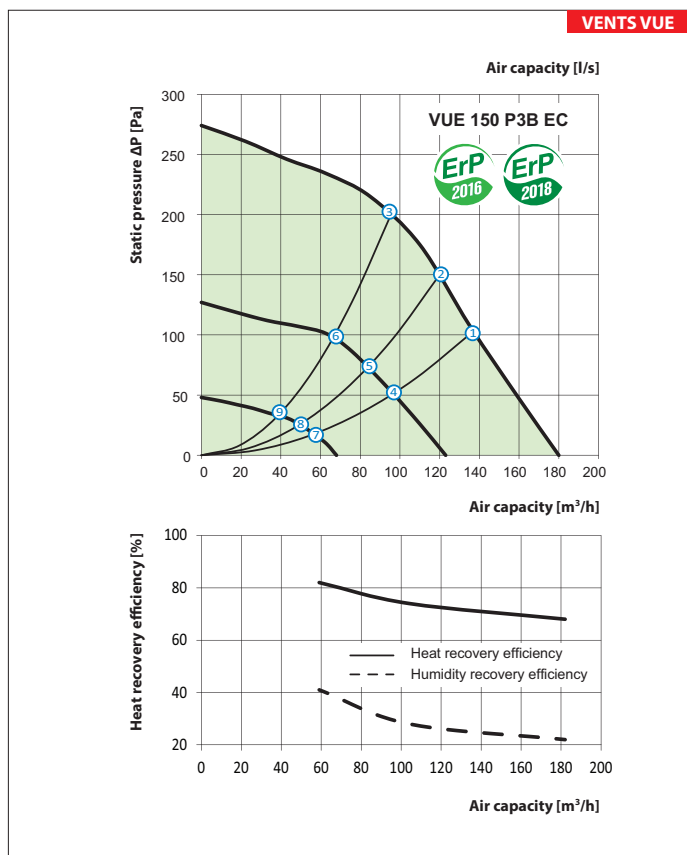

Point	Unit power [W]		
	VUE 150 P3B EC A14	VUE 250 P3B EC A14	VUE 350 P3B EC A14
1	64	80	147
2	61	67	145
3	55	59	144
4	26	43	75
5	24	34	73
6	23	28	70
7	13	23	21
8	13	22	21
9	13	19	20